

FOR OFFICIAL USE

--	--	--	--	--	--

Total
mark

--

X100/101

NATIONAL
QUALIFICATIONS
2004

FRIDAY, 21 MAY
1.00 PM – 1.35 PM

MATHEMATICS
INTERMEDIATE 1
Units 1, 2 and 3
Paper 1
(Non-calculator)

Fill in these boxes and read what is printed below.

Full name of centre

--

Town

--

Forename(s)

--

Surname

--

Date of birth

Day Month Year

--	--	--	--	--	--	--	--

Scottish candidate number

--	--	--	--	--	--	--	--	--	--

Number of seat

--

- 1 You may **NOT** use a calculator.
- 2 Write your working and answers in the spaces provided. Additional space is provided at the end of this question-answer book for use if required. If you use this space, write clearly the number of the question involved.
- 3 Full credit will be given only where the solution contains appropriate working.
- 4 Before leaving the examination room you must give this book to the invigilator. If you do not you may lose all the marks for this paper.



FORMULAE LIST

Circumference of a circle: $C = \pi d$

Area of a circle: $A = \pi r^2$

Theorem of Pythagoras:

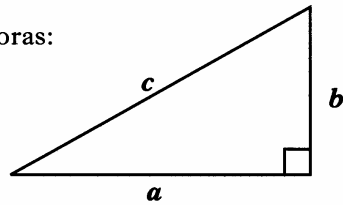

$$a^2 + b^2 = c^2$$

Trigonometric ratios
in a right angled
triangle:

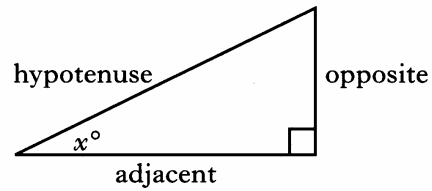

$$\tan x^\circ = \frac{\text{opposite}}{\text{adjacent}}$$

$$\sin x^\circ = \frac{\text{opposite}}{\text{hypotenuse}}$$

$$\cos x^\circ = \frac{\text{adjacent}}{\text{hypotenuse}}$$

ALL questions should be attempted.

Marks

1. Work out the answers to the following.

(a) 30% of £230

1

(b) $\frac{4}{7}$ of 105

1

(c) $380 - 20 \times 9$

1

2. A cooker can be bought by paying a deposit of £59 followed by 12 instalments of £45.

Calculate the total price of the cooker.

2

[Turn over

Marks

3. Calculate the volume of this cuboid.

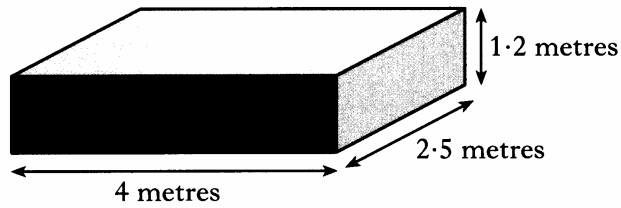

2

4. The temperatures, in degrees Celsius, at noon for the first ten days in January at Invergow were:

-3 0 -2 2 -1 -4 -5 -3 1 3.

Calculate

(a) the median temperature;

2

(b) the range.

2

Marks

4. (continued)

(c) The corresponding values of the median and the range for Abergrange are 2 °C and 5 °C respectively.

Make **two** comments comparing the temperatures in Invergow and Abergrange.

2

5. Solve algebraically the equation

$$11 + 5x = 2x + 29.$$

3

[Turn over

Marks

6. A shop sells artificial flowers.
The prices of individual flowers are shown below.

Variety	Price
Carnation	£2
Daffodil	£3.50
Lily	£4
Iris	£3
Rose	£4.50

- Zara wants to
- buy 3 flowers
 - choose 3 different varieties
 - spend a **minimum** of £10.

One combination of flowers that Zara can buy is shown in the table below.

Carnation	Daffodil	Lily	Iris	Rose	Total Price
		✓	✓	✓	£11.50

Complete the table to show **all** the possible combinations that Zara can buy.

3

Marks

7. An Internet provider has a customer helpline. The length of each telephone call to the helpline was recorded one day. The results are shown in the frequency table below.

Length of call (to nearest minute)	Frequency	Length of call \times Frequency
1	15	15
2	40	80
3	26	78
4	29	116
5	49	
6	41	
	Total = 200	Total =

- (a) Complete the table above and find the mean length of call.

- (b) Write down the modal length of call.

3

1

[Turn over

8. (a) Complete the table below for $y = 3 - x$.

x	-2	2	7
y			

(b) Draw the line $y = 3 - x$ on the grid.

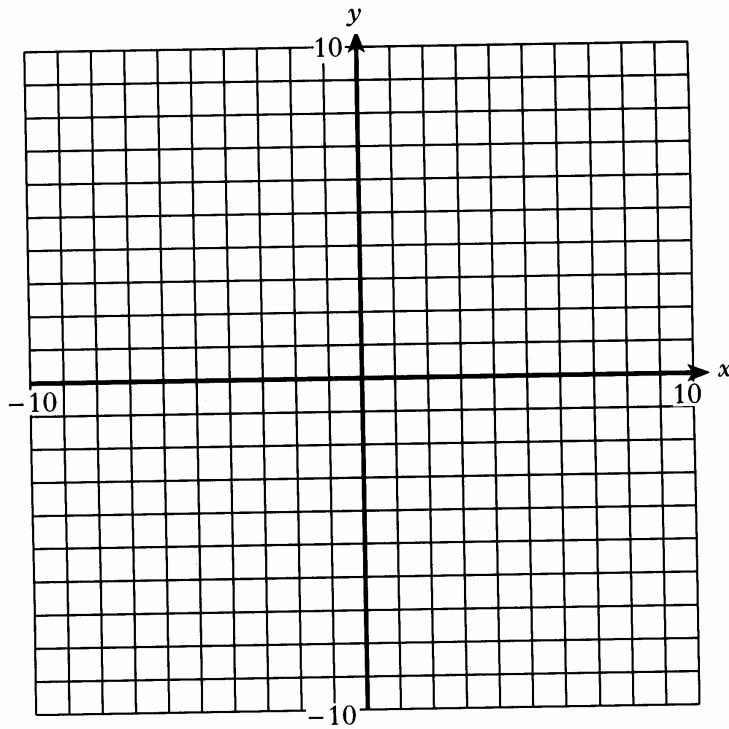

Marks

2

2

FOR OFFICIAL USE

--	--	--	--	--	--

Total
mark

--

X100/103

NATIONAL
QUALIFICATIONS
2004

FRIDAY, 21 MAY
1.55 PM – 2.50 PM

MATHEMATICS
INTERMEDIATE 1
Units 1, 2 and 3
Paper 2

Fill in these boxes and read what is printed below.

Full name of centre

--

Town

--

Forename(s)

--

Surname

--

Date of birth

Day Month Year

--	--	--	--	--	--	--	--

Scottish candidate number

--	--	--	--	--	--	--	--	--	--

Number of seat

--

- 1 You may use a calculator.**
- 2 Write your working and answers in the spaces provided. Additional space is provided at the end of this question-answer book for use if required. If you use this space, write clearly the number of the question involved.**
- 3 Full credit will be given only where the solution contains appropriate working.**
- 4 Before leaving the examination room you must give this book to the invigilator. If you do not you may lose all the marks for this paper.**



FORMULAE LIST

Circumference of a circle: $C = \pi d$

Area of a circle: $A = \pi r^2$

Theorem of Pythagoras:

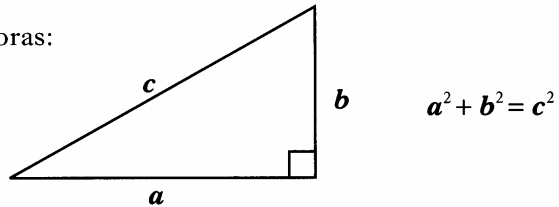

$$a^2 + b^2 = c^2$$

Trigonometric ratios
in a right angled
triangle:

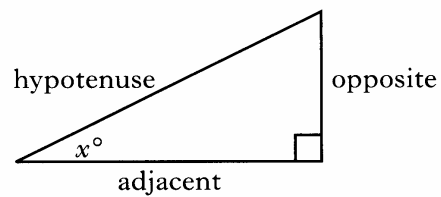

$$\tan x^\circ = \frac{\text{opposite}}{\text{adjacent}}$$

$$\sin x^\circ = \frac{\text{opposite}}{\text{hypotenuse}}$$

$$\cos x^\circ = \frac{\text{adjacent}}{\text{hypotenuse}}$$

Marks

ALL questions should be attempted.

1. 2000 tickets are sold for a raffle in which the star prize is a television.
Kirsty buys 10 tickets for the raffle.
What is the probability that she wins the star prize?

1

2. (a) On the grid below, plot the points $A(-3, 4)$, $B(2, 4)$ and $C(6, -5)$.

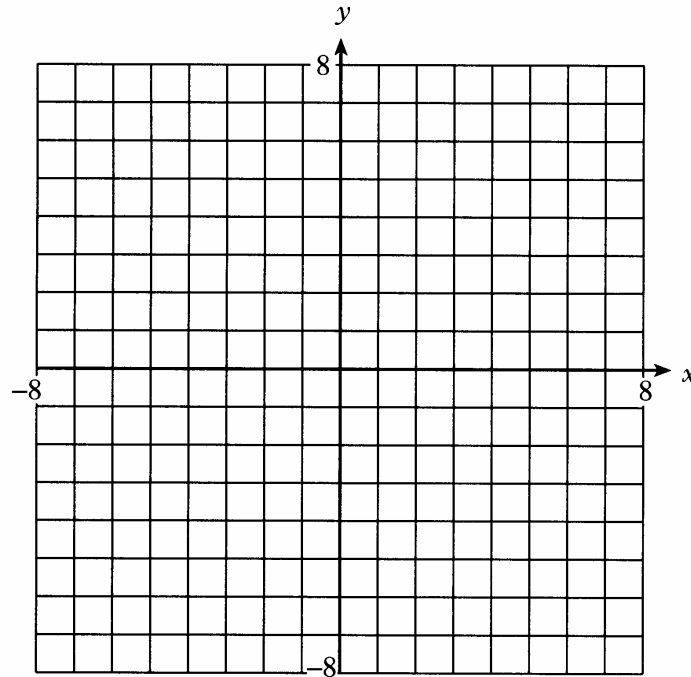

2

- (b) Plot the point D so that shape $ABCD$ is a kite.
Write down the coordinates of point D .

2

[Turn over

Marks

3. An overnight train left London at 2040 and reached Inverness at 0810 the next day.

The distance travelled by the train was 552 miles.

Calculate the average speed of the train.

3

4. Solve algebraically the inequality

$$8n - 3 < 37.$$

2

Marks

5. The scattergraph shows the age and mileage of cars in a garage.

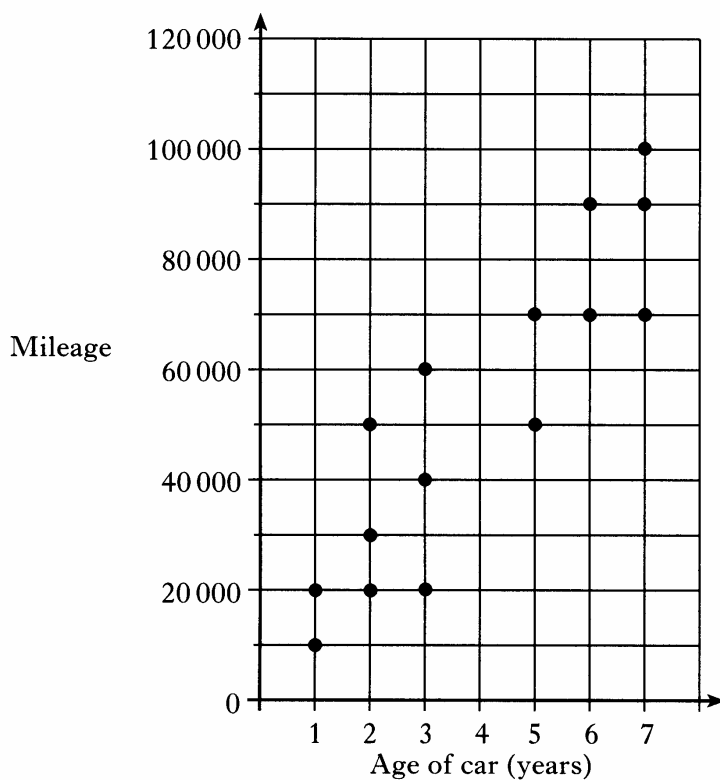

- (a) Draw a line of best fit through the points on the graph.
- (b) Use your line of best fit to estimate the mileage of a 4 year old car.

1

1

6. (a) Multiply out the brackets and simplify

$$2(4 - t) + 5t.$$

- (b) Factorise $10y - 35.$

2

2

Marks

7. Ryan wants to take out a life insurance policy.
The insurance company charges a monthly premium of £2.50 for each £1000 of cover.
Ryan can afford to pay £90 per month.
How much cover can he get?

2

8. (a) In a jewellery shop the price of a gold chain is proportional to its length.
A 16 inch gold chain is priced at £40.
Calculate the price of a 24 inch gold chain.

2

- (b) The gold chains are displayed diagonally on a **square** board of side 20 inches.
The longest chain stretches from corner to corner.
Calculate the length of the longest chain.

Do not use a scale drawing.

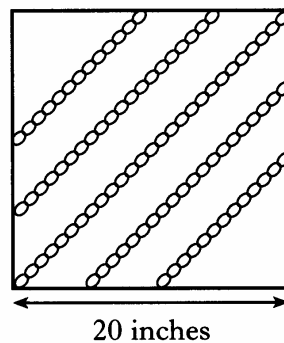

3

Marks

9. Andy buys a bottle of aftershave in Spain for 38.50 euros.
The same bottle of aftershave costs £25.99 in Scotland.
The exchange rate is £1 = 1.52 euros.
Does he save money by buying the aftershave in Spain?
Explain your answer.

10. The front of the tent shown below is an isosceles triangle.

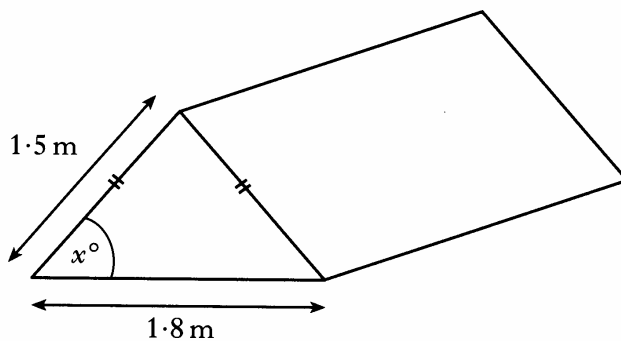

The size of the angle between the side and the bottom of the tent is x° .
Calculate x .

3

4

Marks

11. The graph below shows how the rate of interest for a savings account with the Clydeside Bank changed during 2002.

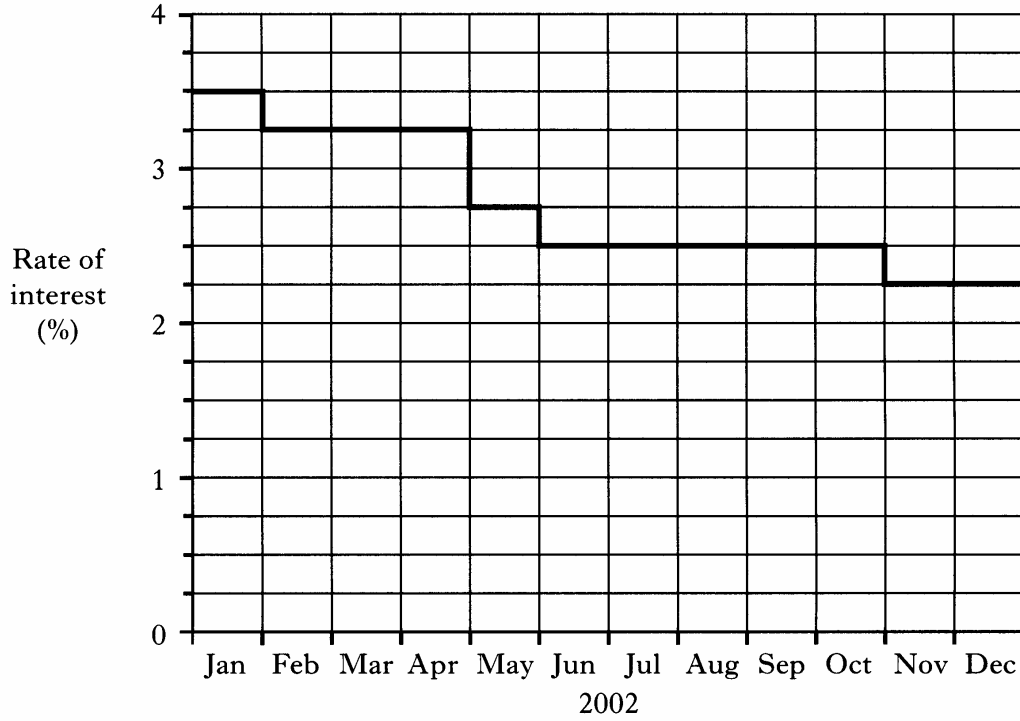

- (a) What was the interest rate in March?
- (b) Describe the trend of the interest rate during the year.
- (c) In June £1400 was invested in this account.
How much interest was due after 3 months?

1

1

4

Marks

12. The minimum velocity v metres per second, allowed at the top of a loop in a roller coaster, is given by the formula

$$v = \sqrt{gr}$$

where r metres is the radius of the loop.

Calculate the value of v when $g = 9.81$ and $r = 9$.

3

13. 40 people were asked whether they preferred tea or coffee.
18 of them said they preferred coffee.
•What percentage said they preferred coffee?

3

[Turn over

Marks

14. The diagram below shows a rectangular door with a window.

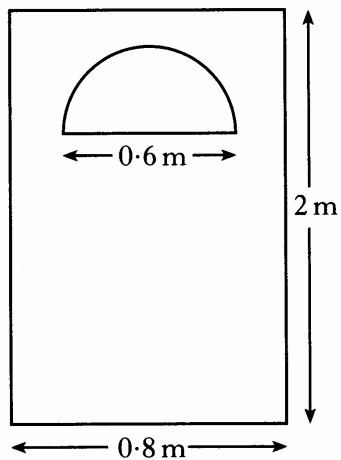

- The window is in the shape of a semi-circle and is made of glass. The rest of the door is made of wood. Calculate the area of the wooden part of the door. Give your answer in square metres correct to two decimal places.

5

[END OF QUESTION PAPER]